

## FEATURES

- Plastic package has Underwriters Laboratory Flammability Classification 94V-0
- Construction utilizes void-free molded plastic technique
- Low forward voltage drop, high efficiency
- High current capability
- High reliability
- High temperature soldering guaranteed: 260°C/10 seconds at terminals
- Component in accordance to RoHS 2011/65/EU

## MECHANICAL DATA

- Case: JEDEC DO-41 molded plastic body
- Terminals: Plated axial leads, solderable per MIL-STD-750, method 2026
- Polarity: color band denotes cathode end
- Mounting Position: Any

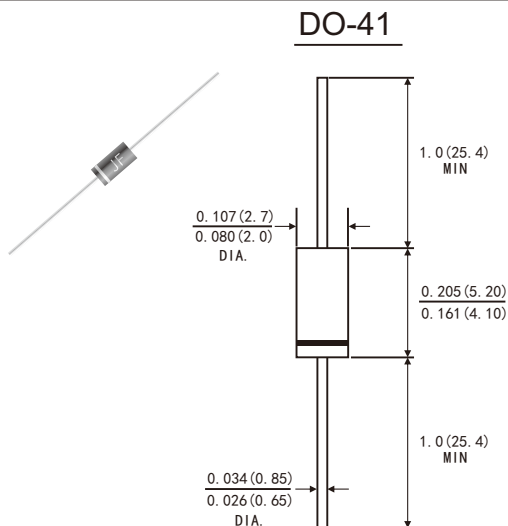

Dimensions in inches and (millimeters)

## MAXIMUM RATINGS AND ELECTRICAL CHARACTERISTICS

(Rating at 25°C ambient temperature unless otherwise specified. Single phase, half wave, 60Hz, resistive or inductive load. For capacitive load, derate current by 20%.)

	Symbols	FR 101G	FR 102G	FR 103G	FR 104G	FR 105G	FR 106G	FR 107G	Units
Maximum Recurrent Peak Reverse Voltage	V <sub>RRM</sub>	50	100	200	400	600	800	1000	Volts
Maximum RMS Voltage	V <sub>RMS</sub>	35	70	140	280	420	560	700	Volts
Maximum DC Blocking Voltage	V <sub>DC</sub>	50	100	200	400	600	800	1000	Volts
Maximum Average Forward Rectified Current	I(AV)	1.0							Amps
Peak Forward Surge Current 8.3ms single half sine-wave superimposed on rated load (JEDEC method)	I <sub>FSM</sub>	30.0							Amps
Maximum Instantaneous Forward Voltage at 1.0 A	V <sub>F</sub>	1.3							Volts
Maximum DC Reverse Current at rated DC blocking voltage	T <sub>A</sub> =25°C	5.0							μA
	T <sub>A</sub> =100°C								
Typical thermal resistance junction to ambient	R <sub>θJA</sub>	50							°C/W
Maximum reverse recovery time(Note 1)	t <sub>rr</sub>	150				250	500		ns
Typical junction capacitance(Note 2)	C <sub>J</sub>	15.0							pF
Operating junction and storage temperature range	T <sub>J</sub> T <sub>STG</sub>	-55 to +150							°C

Note: 1. Test conditions: I<sub>F</sub>=0.5A, I<sub>R</sub>=1.0A, I<sub>RR</sub>=0.25A.

2. Measured at 1MHz and applied reverse voltage of 4.0 Volts D.C.

# RATINGS AND CHARACTERISTIC CURVES FR101G THRU FR107G

FIG.1-TYPICAL FORWARD CURRENT DERATING CURVE

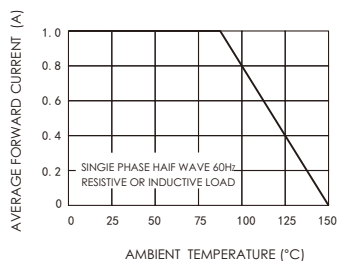

FIG.2-MAXIMUM NON-REPETITIVE FORWARD SURGE CURRENT

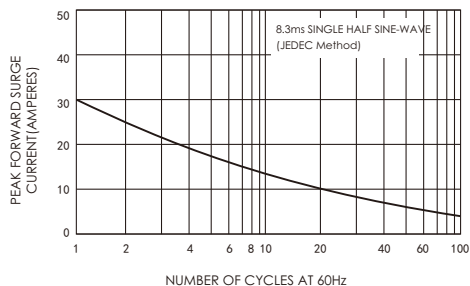

FIG.3-TYPICAL INSTANTANEOUS FORWARD CHARACTERISTICS

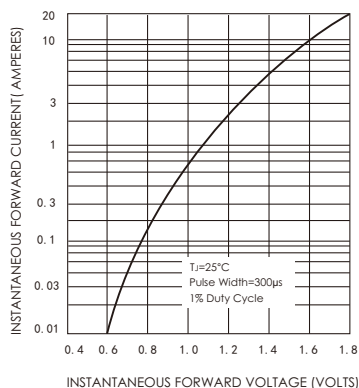

FIG.4-TYPICAL REVERSE CHARACTERISTICS

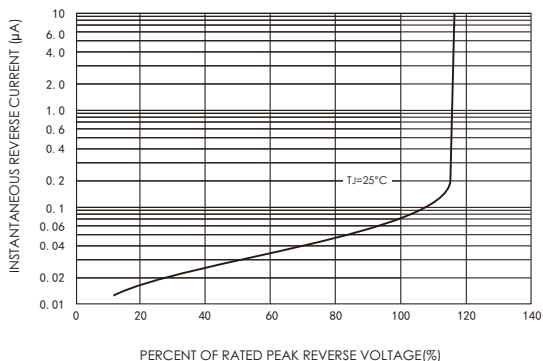

FIG.5-TYPICAL JUNCTION CAPACITANCE

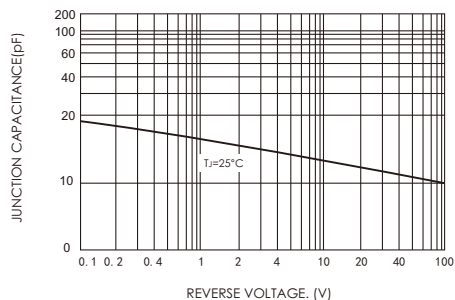

FIG.6-TEST CIRCUIT DIAGRAM AND REVERSE RECOVERY TIME CHARACTERISTIC

